

# 1000 Saint-Jean Boulevard, Pointe-Claire, QC, H9R 5P1

## Suite #202

The 1000 Saint-Jean is located on a central point in Pointe-Claire. Surrounded by many services, the building has good accessibility, either by public transport or by major highways.

Easy access to some services on the ground floor of the building: restaurants, government services and banking. A large parking lot in front of the building is available for employees.

### Building characteristics

TOTAL LEASING AREA	110,000 sq. ft.
NUMBER OF FLOORS	7
ASCENCEURS	2
OPTICAL FIBER	Yes
SPRINKLERS	Yes
GENERATOR	Yes
SECURITY	Acces cards and cameras
BUILDING SERVICES	Restaurants, convenience store, bank

### BUILDING ACCESSIBILITY

INDOOR PARKING	35
OUTDOOR PARKING	380
ROAD ACCESS	Brunswick Boulevard, De Salaberry Blvd., Saint-Jean Blvd., Trans-Canada Highway
BUS	200, 201, 202, 203, 204, 208, 2015, 216, 225, 419
TRAIN STATION	Vaudreuil-Hudson line, Station: Pointe Claire (4.1 km)

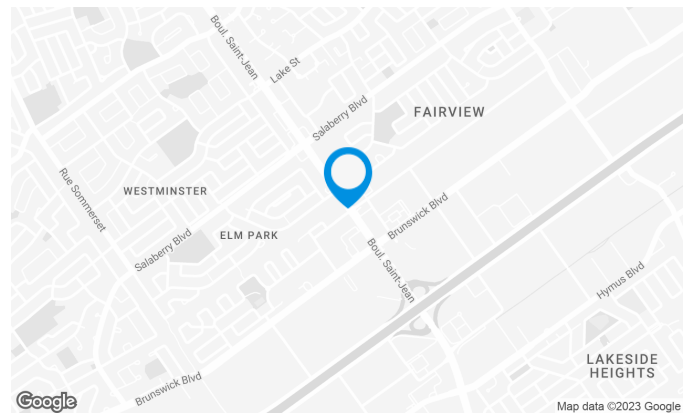

**Xavier Martin**

LEASING DIRECTOR  
LEASING - OFFICES, MONTREAL AREA

**T** 514 737-3344 #3454  
**C** 514 346-3041  
**E** XAVIER.MARTIN@COMINAR.COM

# 1000 Saint-Jean Boulevard, Pointe-Claire, QC, H9R 5P1

## Suite #202



### Space characteristics

AVAILABLE LEASING AREA	984 sq. ft.
NUMBER OF FLOORS	1
FLOOR AREA	13,500 sq. ft.
ADDITIONAL RENT	\$15.96 /sq. ft.
ENERGY	Included
COMMENTS / NOTES	This local has existing improvements.

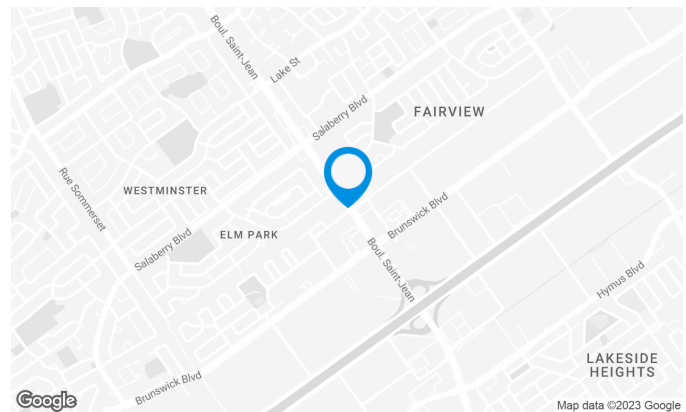
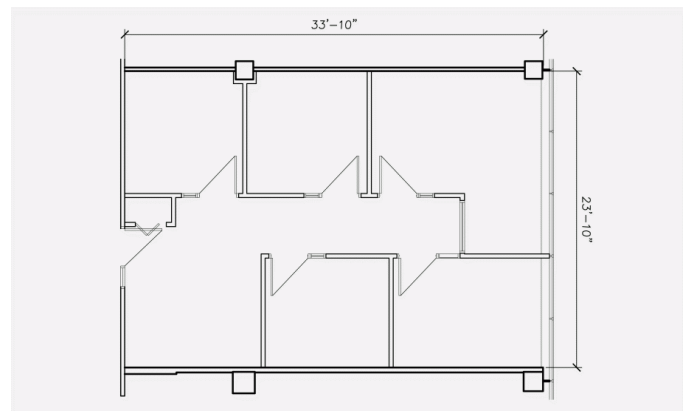
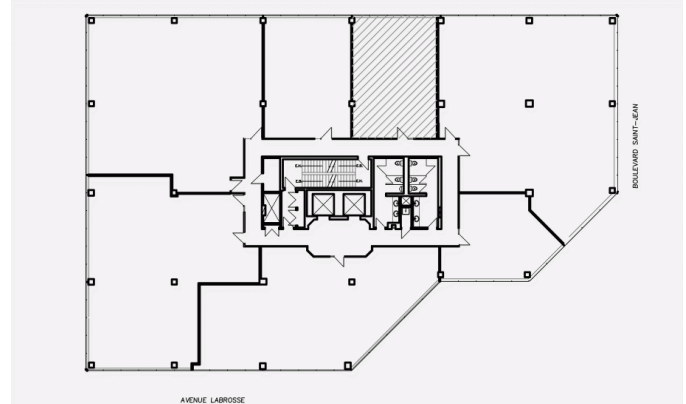

**Xavier Martin**

LEASING DIRECTOR  
LEASING - OFFICES, MONTREAL AREA

**T** 514 737-3344 #3454  
**C** 514 346-3041  
**E** XAVIER.MARTIN@COMINAR.COM

LOCATION PLAN

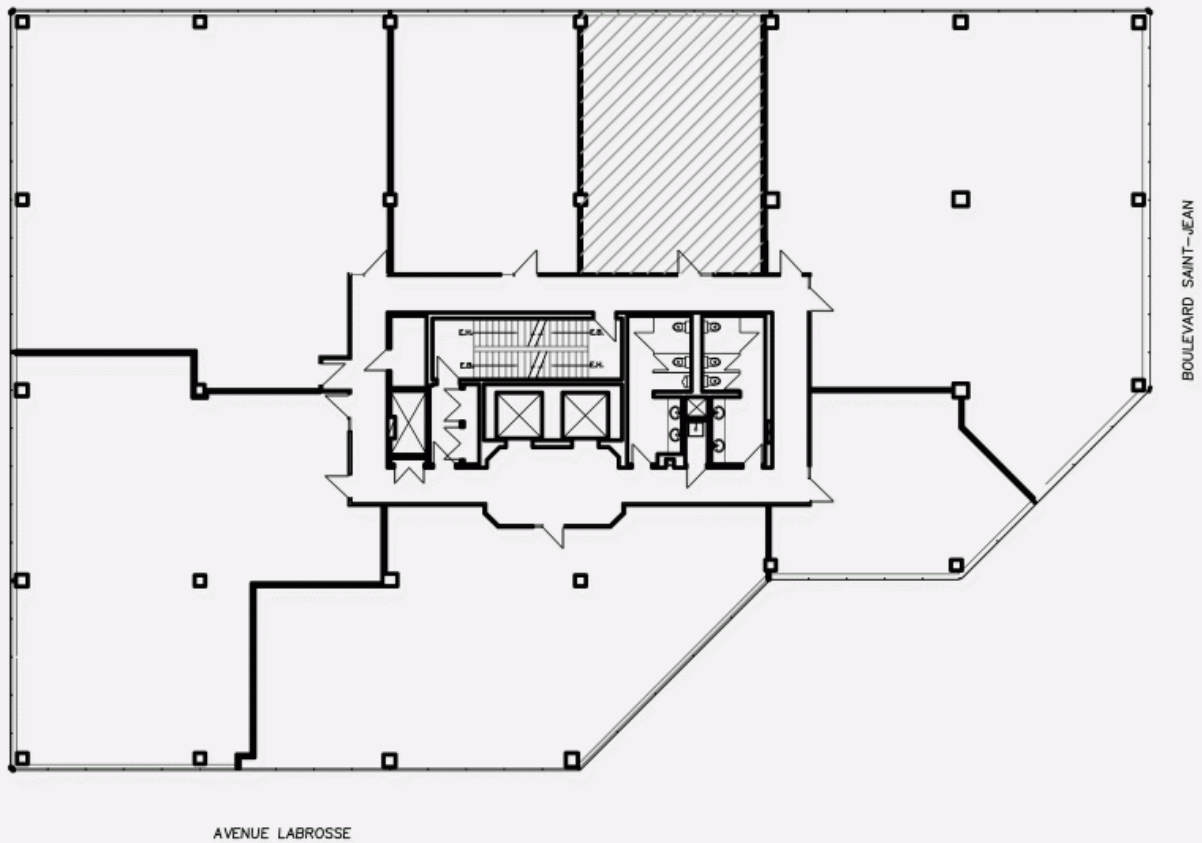

LAYOUT PLAN

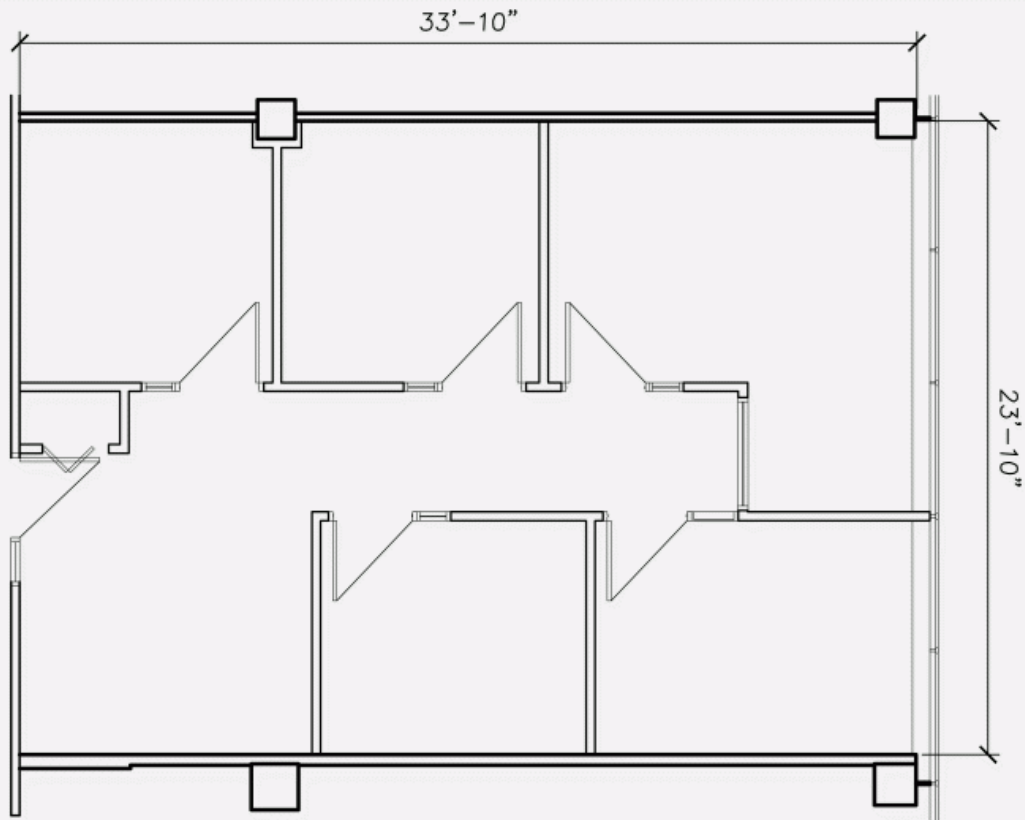

**1000 Saint-Jean Boulevard, Pointe-Claire, QC, H9R 5P1**  
**Suite #202**

