

# 8200 Décarie Boulevard, Montreal, QC, H4P 2J8

## Suite #301



Located along the Décarie Expressway and near the Metropolitan (40) highway. Great visibility, easily accessible and close to de la Savane Metro.

### Building characteristics

TOTAL LEASING AREA	60,889 ft <sup>2</sup>
NUMBER OF FLOORS	3
ASCENCEURS	2
OPTICAL FIBER	Yes
SPRINKLERS	Yes
HVAC HOURS	Monday to Friday: 8 AM to 6 PM
SECURITY	Access cards
BUILDING SERVICES	Toronto Dominion Bank, dental clinic

### BUILDING ACCESSIBILITY

OUTDOOR PARKING	399
ROAD ACCESS	Decarie Highway (15), Royalmount Avenue, Trans-Canada Highway (40)
BUS	17, 368, 371, 382
METRO STATION	De la Savane



**Xavier Martin**

LEASE AGENT  
LEASING - OFFICES

**T** 514 737-3344 #3454

**C** 514 346-3041

**E** XAVIER.MARTIN@COMINAR.COM

## Space characteristics

AVAILABLE LEASING AREA	1,940 ft <sup>2</sup>
AVAILABILITY	Immediate
NUMBER OF FLOORS	1
FLOOR AREA	20,597 ft <sup>2</sup>
ADDITIONNAL RENT	\$14.25 /ft <sup>2</sup>
ENERGY	Included
COMMENTS / NOTES	This local has existing improvements and is contiguous to suite 300. Daily cleaning is included.

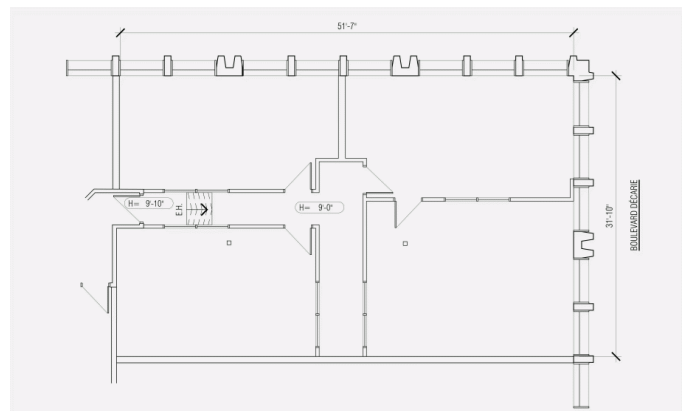
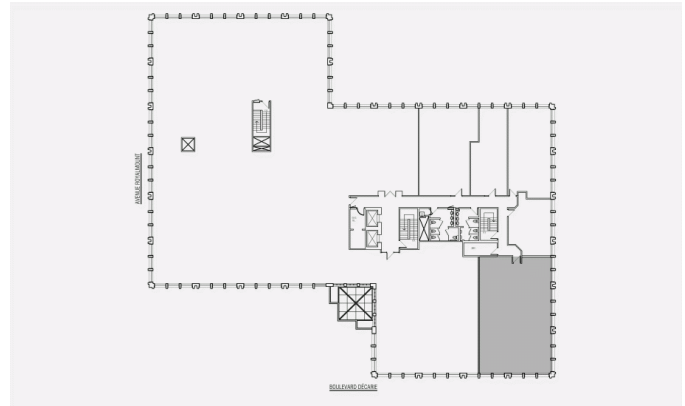

**Xavier Martin**

LEASE AGENT  
LEASING - OFFICES

**T** 514 737-3344 #3454

**C** 514 346-3041

**E** XAVIER.MARTIN@COMINAR.COM

LOCATION PLAN

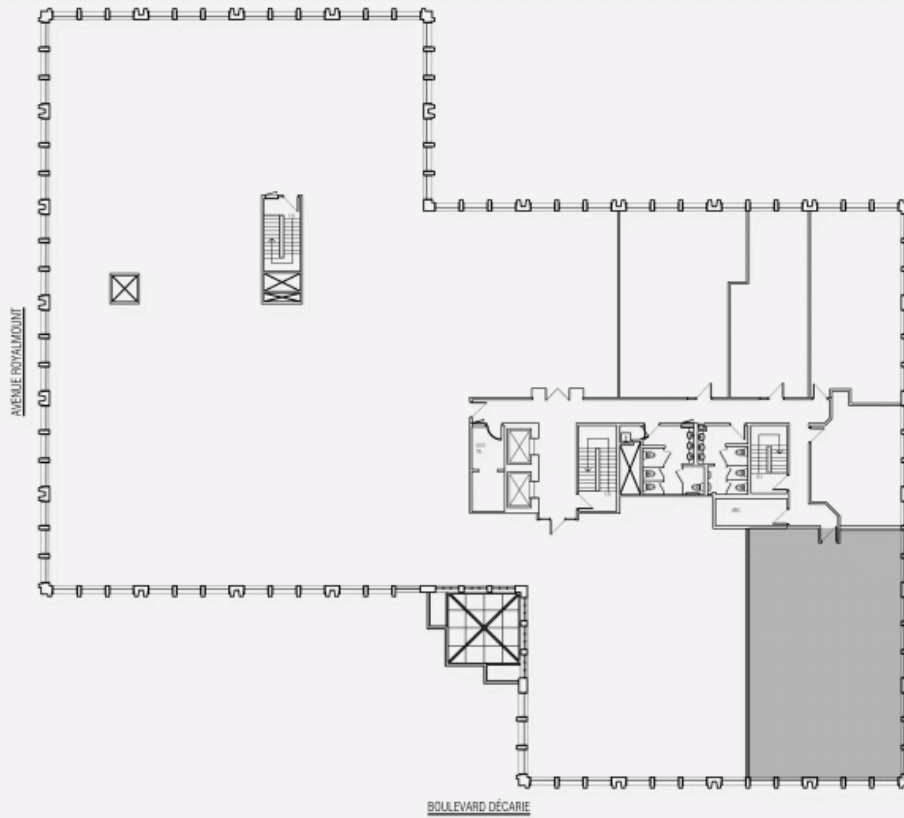

LAYOUT PLAN

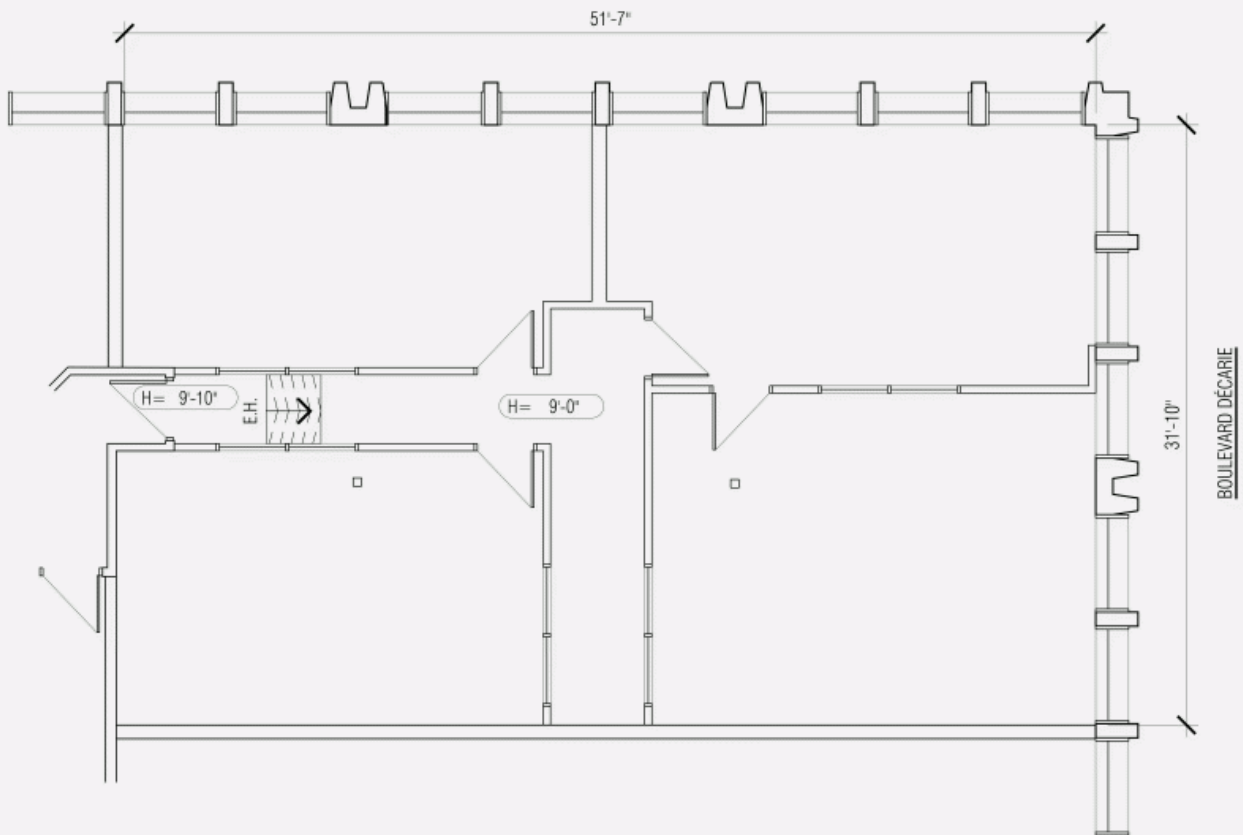

**8200 Décarie Boulevard, Montreal, QC, H4P 2J8**  
**Suite #301**

