

7450 des Galeries-d'Anjou Boulevard, Montreal, QC, H1M

3M3

Suite #140

Strategic location at the intersection of highways 40 & 25 makes it easily accessible. Across the street from Galeries d'Anjou Shopping Centre. Bus service at doorstep and minutes away from the Radisson metro station.

Building characteristics

TOTAL LEASING AREA	64,475 ft ²
NUMBER OF FLOORS	5
ASCENCEURS	2
OPTICAL FIBER	Yes
SPRINKLERS	Yes
GENERATOR	Yes
HVAC HOURS	Monday to Friday: 7:30 AM to 6:30 PM
SECURITY	Access cards and cameras
BUILDING SERVICES	Dental Center

BUILDING ACCESSIBILITY

INDOOR PARKING	25
OUTDOOR PARKING	128
PARC À VÉLOS DISPONIBLE	Yes
ROAD ACCESS	Bélanger Street, Des Halles Avenue, Louis H. Lafontaine Boulevard (25), Metropolitan Highway (40)
BUS	1, 44, 260
METRO STATION	Radisson
TRAIN STATION	Anjou Station

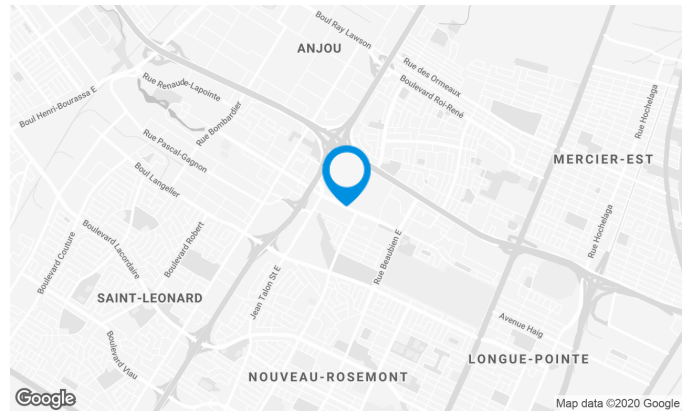

Julie Godbout

LEASING MANAGER
LEASING - OFFICES, MONTREAL AREA

T 514 737-3344 #3485

C 514 238-7079

E JULIE.GODBOUT@COMINAR.COM

AVAILABLE SPACES / OFFICE /

**7450 des Galeries-d'Anjou Boulevard, Montreal, QC, H1M
3M3
Suite #140**



AWARDS

BOMA Best Silver

Space characteristics

AVAILABLE LEASING AREA	738 ft ²
AVAILABILITY	Immediate
FLOOR AREA	11,243 ft ²
ADDITIONAL RENT	\$16.29 /ft ²
ENERGY	Included
COMMENTS / NOTES	Daily cleaning included

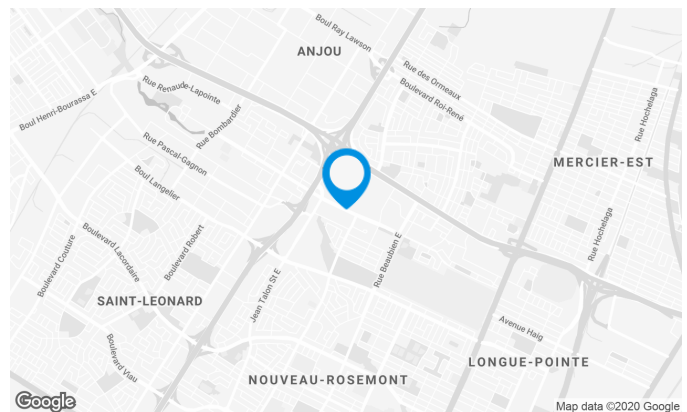
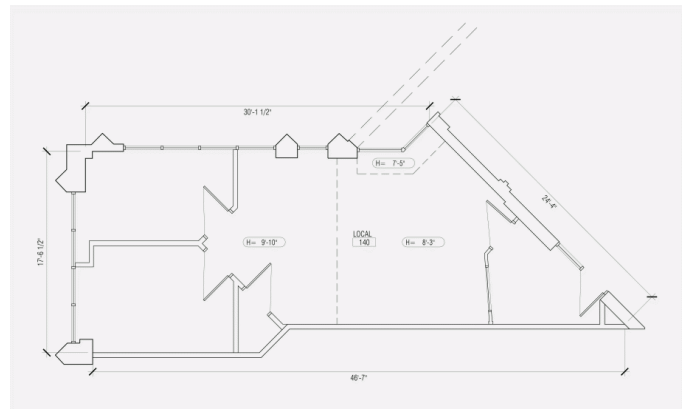
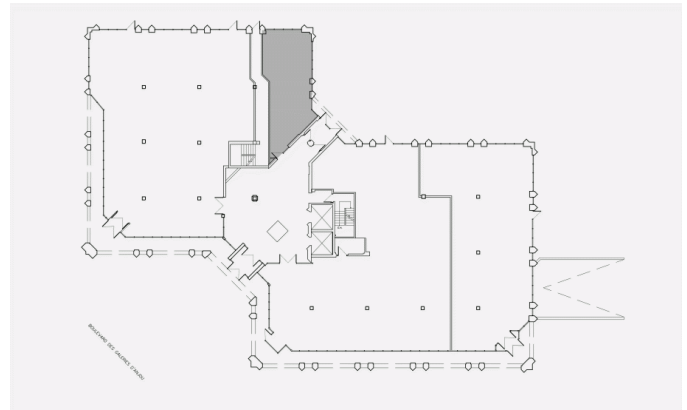

Julie Godbout

LEASING MANAGER
LEASING - OFFICES, MONTREAL AREA

T 514 737-3344 #3485

C 514 238-7079

E JULIE.GODBOUT@COMINAR.COM

LOCATION PLAN

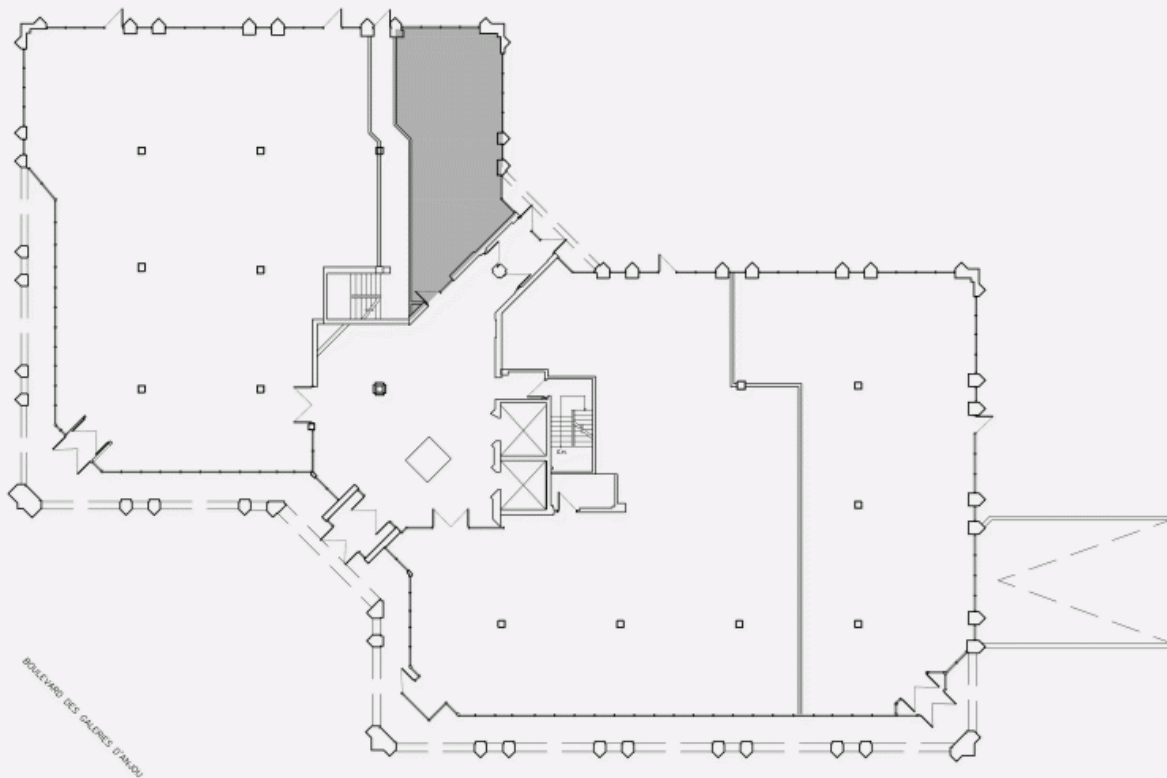

BOULEVARD DES GALERIES D'ANJOU

LAYOUT PLAN

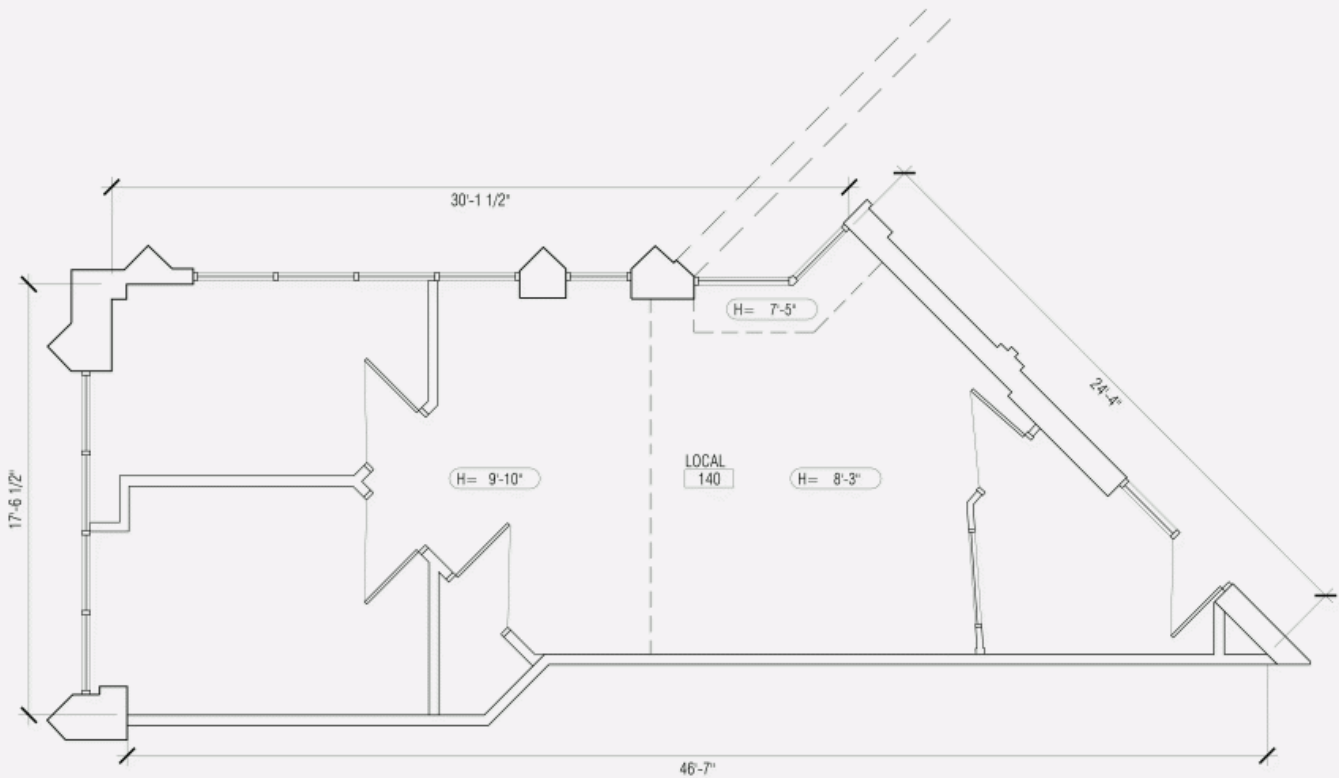

7450 des Galeries-d'Anjou Boulevard, Montreal, QC, H1M

3M3

Suite #140

