

979 de Bourgogne Avenue, Quebec, QC, G1W 2L4

Suite #200

Located in a commercial area of Sainte-Foy, at the intersection of Avenue Duchesneau and Chemin des Quatre-Bourgeois, between the Henri-IV and Duplessis highways.

Building characteristics

TOTAL LEASING AREA	67,149 ft ²
YEAR OF RENOVATION	1996
YEAR OF CONSTRUCTION	1990
NUMBER OF FLOORS	5
ASCENCEURS	2
% COMMON AREA	11
OPTICAL FIBER	Yes
SPRINKLERS	Yes
SECURITY	Card system
BUILDING SERVICES	Secure acces with magnetic card. Free parking.

BUILDING ACCESSIBILITY

OUTDOOR PARKING	145
PARC À VÉLOS DISPONIBLE	Yes
ROAD ACCESS	Chemin des Quatre-Bourgeois / Duplessis Highway
BUS	331/354/800/801

AWARDS

Restaurants, shopping center, grocery and gym nearby.

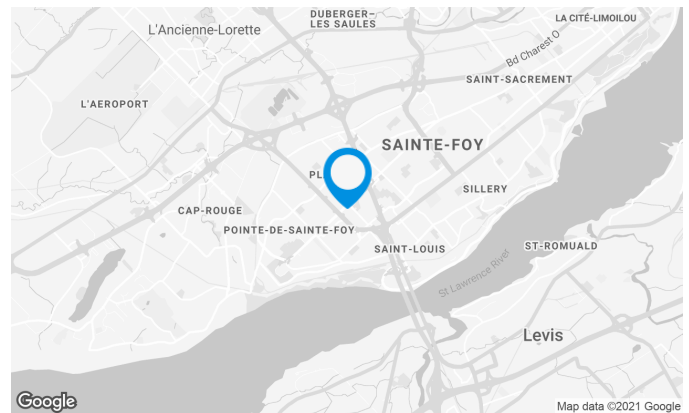

Location Cominar



T 418 681-6300 #2411
E LOCATIONQUEBEC@COMINAR.COM

Space characteristics

AVAILABLE LEASING AREA	962 ft ²
AVAILABILITY	Immediate
NUMBER OF FLOORS	1
FLOOR AREA	13,429 ft ²
ENERGY	Included

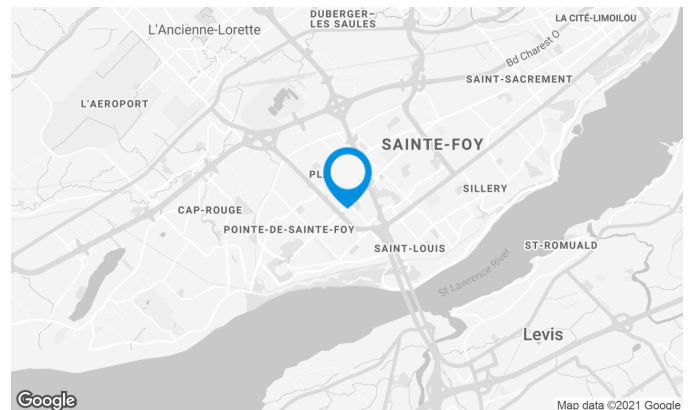
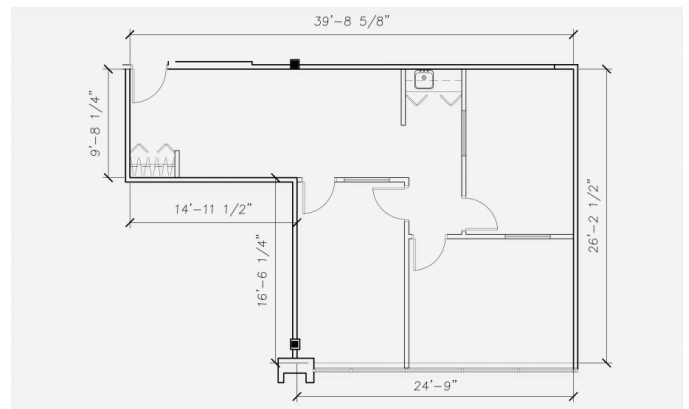
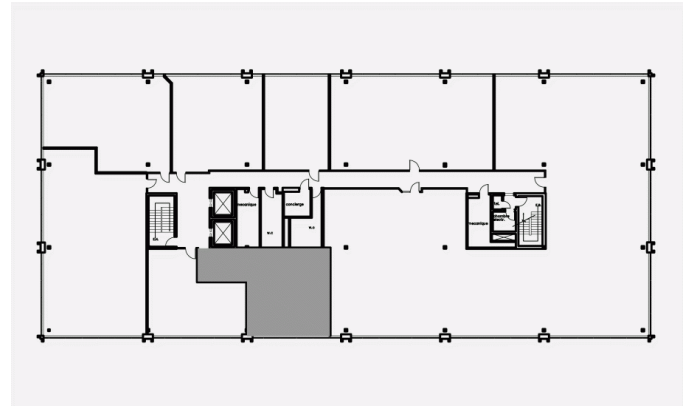

Location Cominar



T 418 681-6300 #2411
E LOCATIONQUEBEC@COMINAR.COM

PLAN - 1

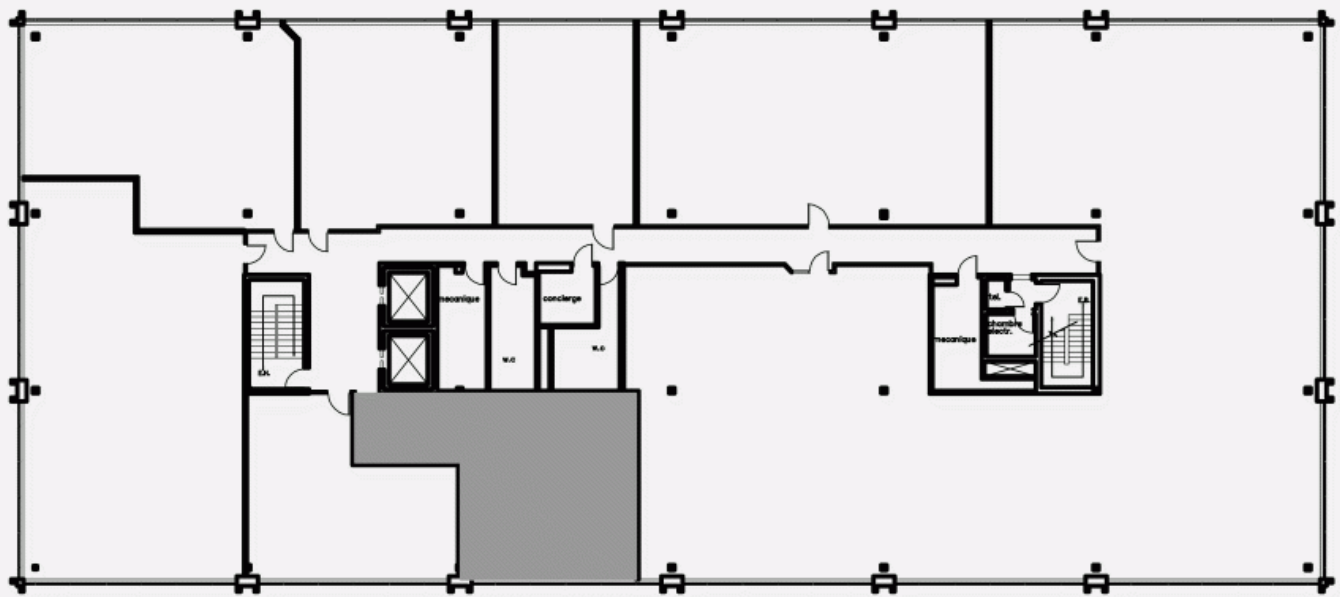

PLAN - 2

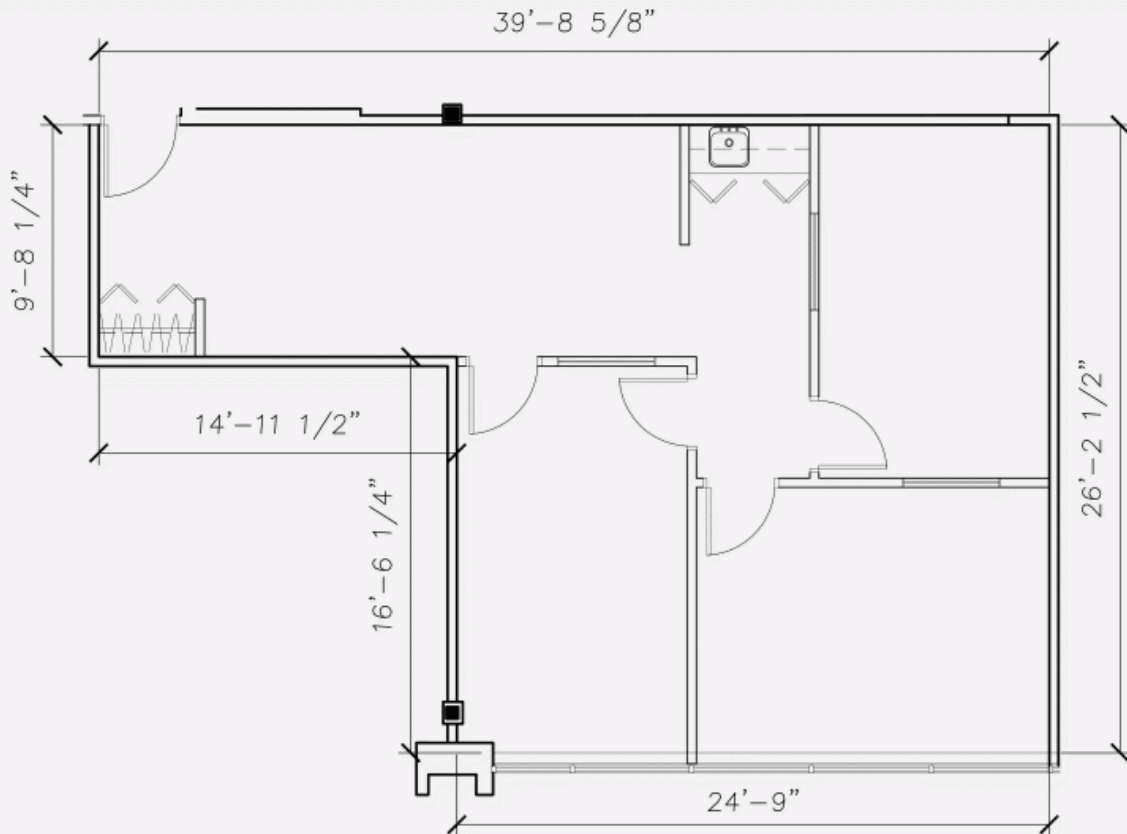

979 de Bourgogne Avenue, Quebec, QC, G1W 2L4
Suite #200

